

RECG - ROUND EGG CRATE GRILLE

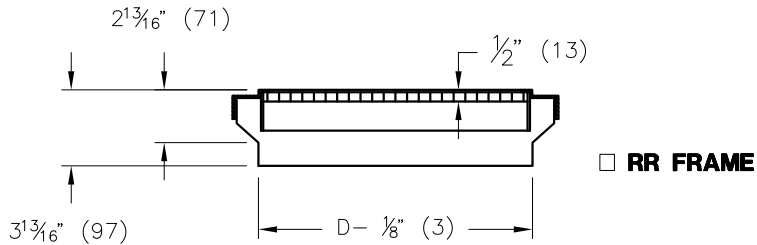
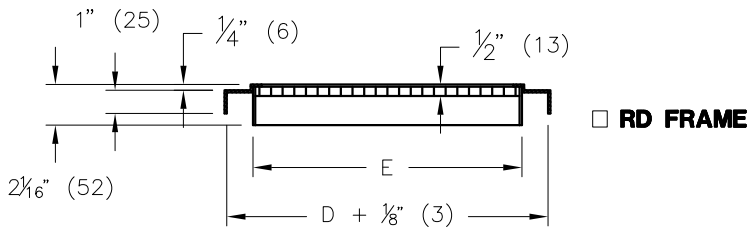
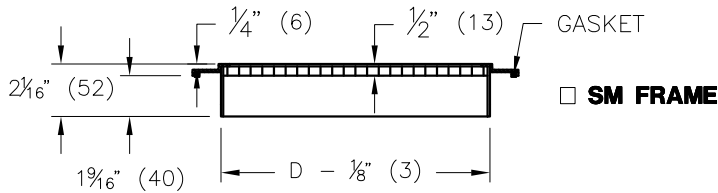
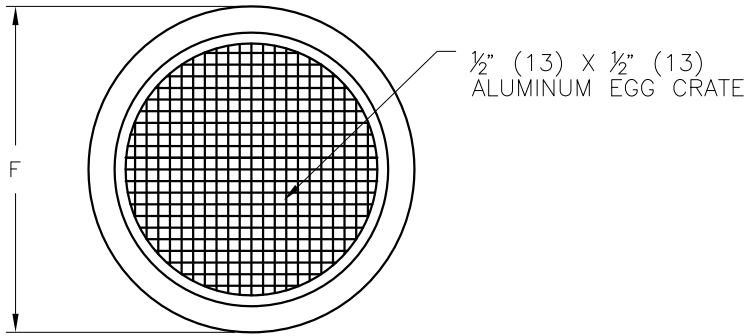

	SM Frame		RD Frame			RR Frame	
SIZE	D	F	D	E	F	D	F
6	6	8 1/4	8	6	8 1/4	6	8 1/4
8	8	10 1/4	10	8	10 1/4	8	10 1/4
10	10	12 1/4	12	10	12 1/4	10	12 1/4
12	12	14 1/4	14	12	14 1/4	12	14 1/4
14	14	16 1/4	16	14	16 1/4	14	16 1/4
16	16	18 1/4	18	16	18 1/4	16	18 1/4
18	18	20 1/4	20	18	20 1/4	18	20 1/4
20	20	22 1/4	22	20	22 1/4	20	22 1/4
22	22	24 1/4	24	22	24 1/4	22	24 1/4
24	24	26 1/4	26	24	26 1/4	24	26 1/4

NOTES:

- AVAILABLE SIZES : MIN. 6", MAX. 24", 2" INCREMENTS.
- CAN BE USED AS SUPPLY, RETURN OR EXHAUST GRILLE.
- FACTORY TOLERANCE ± 1/16" (2).

MATERIAL :

- HEAVY GAUGE ALUMINUM CONSTRUCTION
- 1/2"x1/2" ALUMINUM EGG CRATE
- FOAM GASKET

OPTION:

- SM FRAME - WALL / CEILING MOUNT
- RD FRAME - EXPOSED ROUND DUCT
- RR FRAME - ROUND REDUCER

FINISH :

- B12 WHITE
(OPTIONAL FINISHES AVAILABLE)

ALL METRIC DIMENSIONS () ARE SOFT CONVERTED. IMPERIAL DIMENSIONS ARE CONVERTED TO METRIC AND ROUNDED TO THE NEAREST MILLIMETER.

PROJECT:		PRICE®	
ENGINEER:			
CUSTOMER:		255290	RECG ROUND EGG CRATE GRILLE
SUBMITTAL DATE:	SPEC. SYMBOL:	2010/08/19	

RSG - ROUND SUPPLY GRILLE

BLADE SPACING

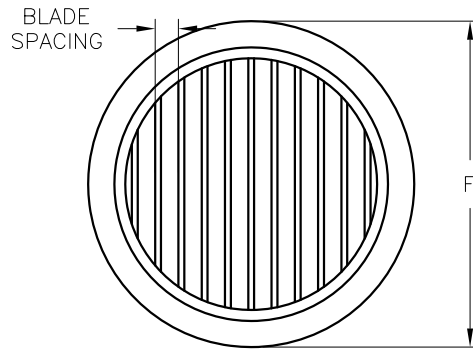

- 1" BLADE SPACING
- 2" BLADE SPACING
- 3" BLADE SPACING SINGLE DEFLECTION (SD) ONLY

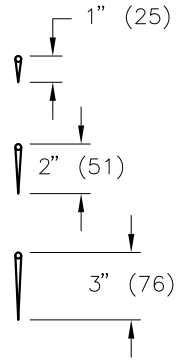

SM FRAME

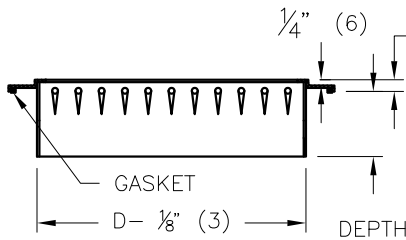

RD FRAME

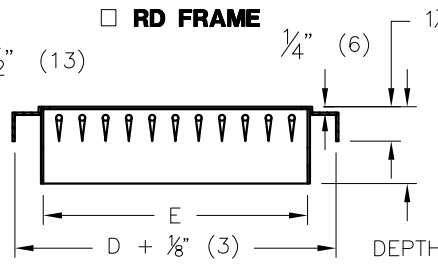

RR FRAME

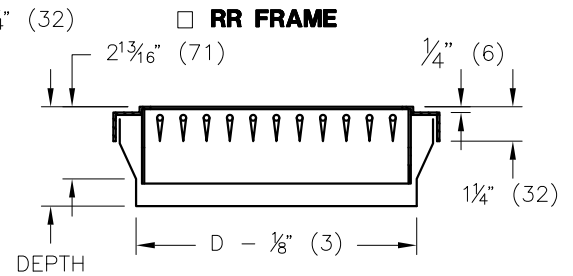

SIZE	D	F
** 6	6	8 $\frac{1}{4}$
* 8	8	10 $\frac{1}{4}$
* 10	10	12 $\frac{1}{4}$
* 12	12	14 $\frac{1}{4}$
* 14	14	16 $\frac{1}{4}$
16	16	18 $\frac{1}{4}$
18	18	20 $\frac{1}{4}$
20	20	22 $\frac{1}{4}$
22	22	24 $\frac{1}{4}$
24	24	26 $\frac{1}{4}$
*** 30	30	32 $\frac{1}{4}$

* SIZES 6 TO 14 NOT AVAILABLE IN SD 3"
 ** SIZE 6 NOT AVAILABLE IN SD AND DD 2"
 *** SIZE 30 NOT AVAILABLE IN SD 1"

DEPTH

DD MODEL WITH 2" BLADE SPACING IS 4 $\frac{1}{16}"$ DEEP
 ALL OTHERS ARE 2 $\frac{1}{16}"$ DEEP

SIZE	D	E	F
** 6	8	6	8 $\frac{1}{4}$
* 8	10	8	10 $\frac{1}{4}$
* 10	12	10	12 $\frac{1}{4}$
* 12	14	12	14 $\frac{1}{4}$
* 14	16	14	16 $\frac{1}{4}$
16	18	16	18 $\frac{1}{4}$
18	20	18	20 $\frac{1}{4}$
20	22	20	22 $\frac{1}{4}$
22	24	22	24 $\frac{1}{4}$
24	26	24	26 $\frac{1}{4}$
*** 30	32	30	32 $\frac{1}{4}$

* SIZES 6 TO 14 NOT AVAILABLE IN SD 3"
 ** SIZE 6 NOT AVAILABLE IN SD AND DD 2"
 *** SIZE 30 NOT AVAILABLE IN SD 1"

DEPTH

DD MODEL WITH 2" BLADE SPACING IS 4 $\frac{1}{16}"$ DEEP
 ALL OTHERS ARE 3 $\frac{1}{16}"$ DEEP

SIZE	D	F
** 6	6	8 $\frac{1}{4}$
* 8	8	10 $\frac{1}{4}$
* 10	10	12 $\frac{1}{4}$
* 12	12	14 $\frac{1}{4}$
* 14	14	16 $\frac{1}{4}$
16	16	18 $\frac{1}{4}$
18	18	20 $\frac{1}{4}$
20	20	22 $\frac{1}{4}$
22	22	24 $\frac{1}{4}$
24	24	26 $\frac{1}{4}$

* SIZES 6 TO 14 NOT AVAILABLE IN SD 3"
 ** SIZE 6 NOT AVAILABLE IN SD AND DD 2"

DEPTH

DD MODEL WITH 2" BLADE SPACING IS 4 $\frac{1}{16}"$ DEEP
 ALL OTHERS ARE 3 $\frac{1}{16}"$ DEEP

MATERIAL :

- ALUMINUM CONSTRUCTION

FINISH :

- DURABLE POWDER COAT FINISH (STANDARD)
 (OPTIONAL FINISHES AVAILABLE)

NOTES:

- INDIVIDUALLY ADJUSTABLE BLADES.
- AVAILABLE SIZES : MIN. 6", MAX. 24", 2" INCREMENTS.
- FACTORY TOLERANCE $\pm \frac{1}{16}" (2)$

ALL METRIC DIMENSIONS () ARE SOFT CONVERTED. IMPERIAL DIMENSIONS ARE CONVERTED TO METRIC AND ROUNDED TO THE NEAREST MILLIMETER.

OPTION:

- SM FRAME – WALL / CEILING MOUNT
- RD FRAME – EXPOSED ROUND DUCT
- RR FRAME – ROUND REDUCER
- SINGLE DEFLECTION (SD)
 (AVAILABLE WITH 1", 2" AND 3" MODELS)
- DOUBLE DEFLECTION (DD)
 (AVAILABLE WITH 1" AND 2" MODELS)

PROJECT:		PRICE®	
ENGINEER:			RSG ROUND SUPPLY GRILLE
CUSTOMER:			
SUBMITTAL DATE:	SPEC. SYMBOL:	2010/08/19	

RPG - ROUND PERFORATED GRILLE

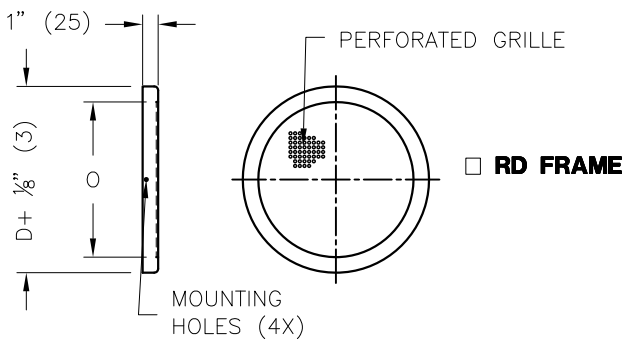
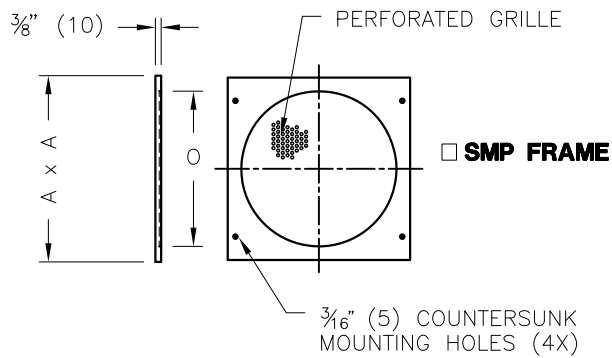
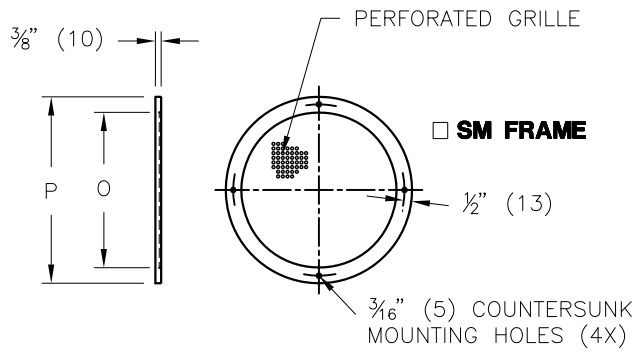

MATERIAL :

- ALUMINUM CONSTRUCTION

NOTES:

- CAN BE USED AS SUPPLY, RETURN OR EXHAUST GRILLE.
- AVAILABLE SIZES : 4", 5", 6", 8", 10", 12", 14" & 16".
- 3 MOUNTING FRAMES
- FACTORY TOLERANCE $\pm 1/16"$ (2)

	SM Frame			SMP Frame		RD Frame	
SIZE	Opening Size O	Duct Size D	Panel Size P	Duct Size DxD	Panel Size AxA	Opening Size O	Duct Size D
4	4	4	6	4x4	6x6	4	6
5	5	5	8	5x5	8x8	5	6
6	6	6	8	6x6	8x8	6	8
8	8	8	10	8x8	10x10	8	10
10	10	10	12	10x10	12x12	10	12
12	12	12	14	12x12	14x14	12	14
14	14	14	16	14x14	16x16	14	16
16	16	16	18	16x16	18x18	16	18

OPTION:

- SM FRAME – WALL / CEILING MOUNT
- SMP FRAME – WALL / CEILING MOUNT
- RD FRAME – EXPOSED ROUND DUCT

FINISH :

- B12 WHITE (STANDARD)
- (OPTIONAL FINISHES AVAILABLE)

ALL METRIC DIMENSIONS () ARE SOFT CONVERTED. IMPERIAL DIMENSIONS ARE CONVERTED TO METRIC AND ROUNDED TO THE NEAREST MILLIMETER.

PROJECT:		PRICE [®]	
ENGINEER:			
CUSTOMER:		ROUND PERFORATED GRILLE	
SUBMITTAL DATE:		255293	
SPEC. SYMBOL:		2010/08/20	